



- **Fully Weatherproof** Allows exposed mounting in mobile applications.
- **Ruggedised** Designed specifically for use in antenna mount applications.
- **Lightweight** Weighs less than 19 kg.
- **EMC** Complies with current worldwide specifications.
- **Power Factor Correction** Broad input voltage range allows connection to portable or mains supplies worldwide.
- **Reliable** Designed and built to provide a high level of reliability in all applications, from fixed ground base to flyaway systems.
- **Digital Operation** High linearity for digital satellite communications.
- **Redundant Control** Contains all the necessary control and drive requirements to implement a basic waveguide switch based redundant system.
- **Stand-Alone Setting** A selectable facility that automatically sequences the unit to the transmit mode, upon application of the mains power. This reduces the complexity of control requirements for 'blackbox' applications.
- **RF Circuit** Includes RF input isolation, RF output isolation, receiver rejection filter and harmonic filter as standard.

The amplifiers can be simply deployed anywhere in the world, are user friendly, and incorporate a comprehensive remote control facility as standard, including RS485.

TYPICAL DATA

Frequency	30.0 to 31.0	GHz
Output power (at output flange)	95	W typical
Small signal gain	75	dB typical
Intermodulation (at 40 W output)	-19	dBc typical
Prime power	99 to 265	V
	47 to 63	Hz
	700	VA typical
Power factor	0.99	typical
Dimensions	500 mm (19.7 inches) long	
	260 mm (10.2 inches) wide	
	228 mm (9.0 inches) high	
Weight	18	kg typical

Options

Options include integral solid-state amplifier and/or gain control.

INTERNAL SCHEMATIC

8042

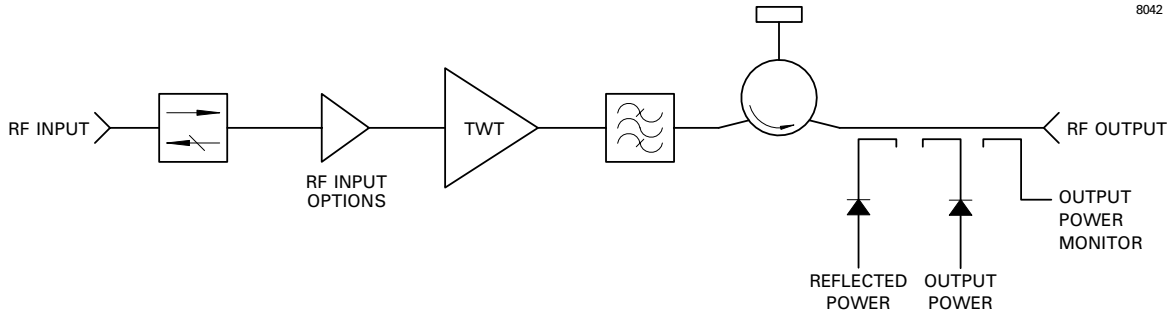

TEST PERFORMANCE (Non-linearised versions)

Frequency	30.0 to 31.0	GHz
Output power (at output flange)	80	W min
Gain at $P_{SAT} - 10$ dB:		
N6812	71	dB min
N6812D	65	dB min
N6812C	47	dB min
N6812CD	41	dB min
Attenuation range (D versions)	30	dB min
Gain variation:		
over any 1 GHz band	3.5	dB max
over any 500 MHz band	2.0	dB max
over any 40 MHz band	1.0	dB max
slope	0.05 dB/MHz	max
Gain stability:		
24 hours (constant drive, temperature and load)	0.5	dB max
over full operating temperature range	2.0	dB max
Input VSWR (non-operating)	1.3:1	max
Load VSWR:		
operate	1.3:1	max
no damage	2.0:1	max
Residual AM:		
< 10 kHz	-50	dBc max
10 to 500 kHz	-20 (1 + log f)	dBc max
> 500 kHz	-85	dBc max
Noise power:		
transmit band	-70 dBW/4 kHz	max
receive band (< 21.2 GHz)	-150 dBW/4 kHz	max
Intermodulation (two equal carriers):		
at 20 W total output	-23	dBc max
at 40 W total output	-17	dBc max
at 50 W total output	-15	dBc max
AM to PM conversion:		
at rated power	6	°/dB
at 4 dB OPBO	2.0	°/dB
Group delay:		
linear	0.01	ns/MHz
parabolic	0.005	ns/MHz ²
ripple	0.5	ns p-p
Phase noise	Intelsat IESS-308	
Harmonic output	-60	dBc max

ELECTRICAL

Prime power	single-phase, line-neutral or line-line
Voltage	99 to 265 V
Frequency	47 to 63 Hz
Power requirement	800 VA max
Power factor	0.95 min

MECHANICAL

Weight	19 kg (41.9 lb) max
Dimensions	see outline
Cooling	integral forced-air

CONNECTORS

RF input	WR-28 UG599/U, with 4 holes 4-40 UNC 2B
RF output	WR-28 UG599/U, with 4 holes 4-40 UNC 2B
Prime power	Hirschmann CA3GS
Control interface	62GB-12E-2041-PN-(219)

Note: Mating connectors for the mains supply serial and control interface are supplied.

ENVIRONMENTAL

For operation outside these parameters, refer to e2v technologies for guidance.

Operating temperature	-40 to +50 °C
Derating	2 °C/300 m above sea level (3.6 °F/1000 ft)
Storage temperature	-40 to +80 °C
Relative humidity (condensing)	100 %
Altitude:	
operating	4.5 km (15,000 ft) max
non-operating	12 km (40,000 ft) max
Vibration	BS EN 60068-2-64 test Fh, transportation
Shock	IEC Publication 68-2-27 Part 2 Test Ea, 25 g
Electromagnetic compatibility	EMC Directive 89/336/EEC
Safety	Low Voltage Directive 73/23/EEC BS EN 60950

CONTROLS

Note: Controls/monitoring marked * are not available via user interface.

TYPE	FUNCTION
LOCAL CONTROL	Off Standby Transmit
LOCAL STATUS/MONITOR	Off Green LED Standby Green LED Transmit Green LED Warm-up Green LED Summary Fault Red LED Output Power Sample
REMOTE CONTROL	Off High Power Alarm Set* Standby Low Power Alarm Set* Transmit Auto Redundancy Control* RF Inhibit RF Switch Control* Gain Control* (when fitted)
REMOTE STATUS/MONITOR	Off High Power Alarm* Warm-up Low Power Alarm* Standby Output Power Monitor* Transmit Reflected Power Monitor* Fault Summary Helix Current Monitor* Reflected Power Helix Voltage* External Interlock Collector Voltage* TWT Too Hot Heater Voltage* Mean Helix Current Anode Voltage* Peak Helix Current Elapsed Hours*
INTERFACES: Serial User	RS-422/485 Dry Relay Contact
Other Features	Auxiliary Output Voltage Redundant system and waveguide switch drive 'Stand Alone' setting for automatic power-up

OPTIONS

Non-Linearised Versions

The basic version is the N6812, which includes a solid-state amplifier (SSA). Options are designated by the following suffices:

- **D** - Includes an electronically variable attenuator (EVA),
- **C** - SSA omitted.

e.g. N6812CD has no SSA but includes an EVA.

Performance is the same for all versions, with the exception of gain. Variations of this parameter are shown in the Test Performance on page 2.

Linearised Versions

Linearisers are available with all the above options and designated by the suffix Z, e.g. N6812DZ. For linearised versions, the third order two-tone intermodulation product (IM3) is guaranteed as:

at 40 W total output -25 dBc max

HEALTH AND SAFETY HAZARDS

e2v technologies electronic devices are safe to handle and operate provided that the relevant precautions are observed. e2v technologies does not accept responsibility for damage or injury resulting from the use of electronic devices it produces.



High Voltage

Dangerous voltages are present within the TWT amplifier when operating normally. However, the equipment is designed so that personnel cannot come into contact with high voltage circuits unless covers are removed.



RF Radiation

All RF connectors must be correctly fitted before operation.



Beryllia

The TWT in the amplifier contains beryllium oxide ceramic parts. These are not accessible unless the TWT casing is damaged. Consult e2v technologies regarding the disposal of damaged or life-expired tubes.

OUTLINE

(All dimensions without limits are nominal)

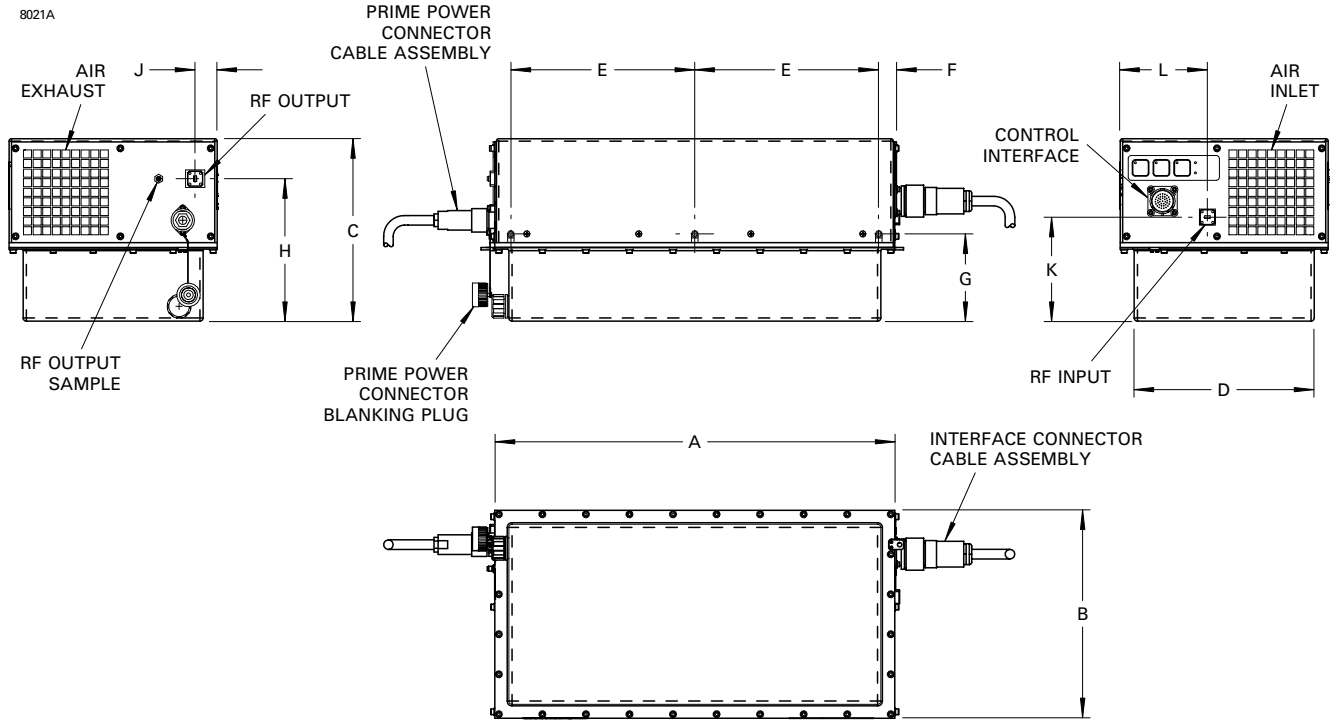

Ref	Millimetres	Inches
A	500.0	19.685
B	260.0	10.236
C	228.0	8.976
D	225.0	8.858
E	230.0 ± 0.2	9.055 ± 0.008
F	20.0	0.787
G	109.0	4.291
H	178.0 ± 1.0	7.008 ± 0.039
J	27.4	1.079
K	130.0 ± 1.0	5.118 ± 0.039
L	109.0 ± 1.0	4.291 ± 0.039

Inch dimensions have been derived from millimetres.

Whilst e2v technologies has taken care to ensure the accuracy of the information contained herein it accepts no responsibility for the consequences of any use thereof and also reserves the right to change the specification of goods without notice. e2v technologies accepts no liability beyond that set out in its standard conditions of sale in respect of infringement of third party patents arising from the use of tubes or other devices in accordance with information contained herein.