

ACTIV 10G Ethernet EMI Filter



The ACTIV 10G is the most advanced EMI filter available for Ethernet connections, providing complete electromagnetic isolation for signals ranging from 10 Mbps to 10 Gbps without impacting network performance. Proprietary DSP (Digital Signal Processing) techniques faithfully reproduce Ethernet signals while rejecting interference from 10kHz to 40GHz at better than 100dB. Designed for both commercial and military-grade environments, the ACTIV 10G ensures uncompromising EMI suppression, long service life, and rugged reliability.

Proprietary DSP Technology for Ultimate Filtering

- Faithfully reproduces Ethernet signals without introducing latency or distortion.
- Maintains signal integrity for fast rise-time digital square waves.
- Invisible to network negotiation and operation.

Built Tough for Demanding Applications

- Machined from solid aluminum for superior mechanical integrity and EMI shielding.
- Robust protection circuitry includes ESD and transient voltage suppressors, gas discharge tubes, and current limiters.
- Suitable for harsh military environments as well as climate-controlled installations.

Universal Mounting System

- Mounts easily and securely on RF shielded enclosures with any wall thickness. Requires a simple, circular mounting hole for use with multiple standard penetration lengths (e.g., short, medium, long) to accommodate different wall types.
- Field-changeable penetrations allow for easy on-the-spot reconfiguration.

Suitable for ICD 705

- Engineered to meet the physical and technical security controls outlined in Intelligence Community Directive (ICD) 705, DoD and EMSEC Standards.
- Offers a trusted alternative to fiber optic penetrations for SCIF, SAPF, and TEMPEST applications.

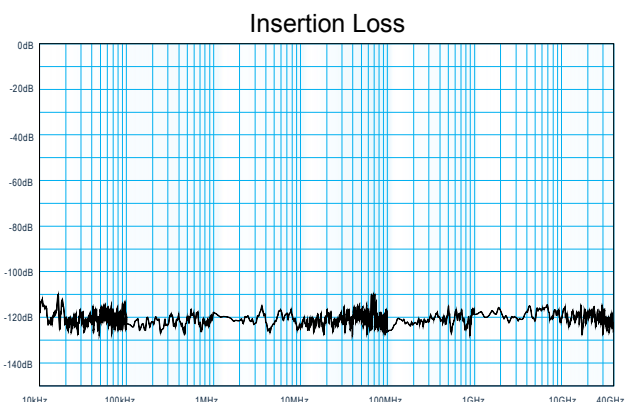
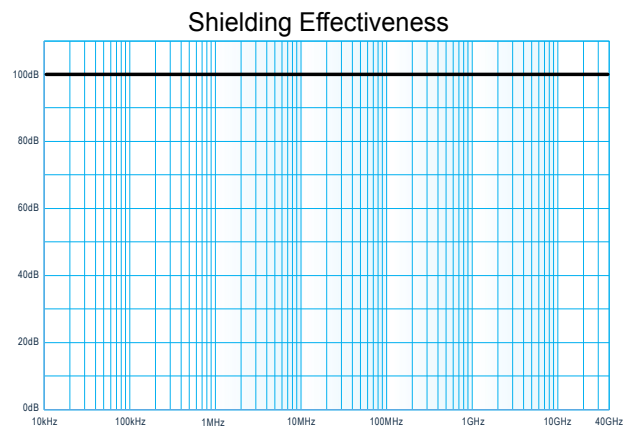

Technical Specifications

Filter Performance	Shielding Effectiveness	>100dB from 10kHz to 40GHz (typical)
	Insertion Loss	>100dB from 50Hz to 40GHz (typical)
	Radiated and Conducted Emissions	Exceeds MIL-STD-461 CE102 Exceeds MIL-STD-461 RE102 Exceeds FCC Part 15 A, B Exceeds EN 55032 Class A, B
Network Performance	Auto MDI/MDI-X	Automatically detects and configures MDI or MDI-X.
	Auto Negotiation	Input and output automatically configure 10Mbps, 100Mbps, 1Gbps, 2.5Gbps, 5Gbps or 10Gbps
	Hot Pluggable	Can be plugged in/out without affecting filter or other links.
	Auto Link Restoration	Automatically re-establishes network link after a link loss.
	Communication Standards	IEEE802.3i 10Base-T (Ethernet) IEEE802.3u 100Base-T (Fast Ethernet) IEEE802.3ab 1000Base-T (Gigabit Ethernet) IEEE802.3an 10GBase-T (10G Ethernet) IEEE802.3bz 2.5GBase-T/5GBase-T (2.5G/5G Ethernet)
Safety and Regulatory	File Number	E362686
	Standards	UL 62368-1 CAN/CSA C22.2 No. 62368-1 EN IEC 62368-1:2020+A11:2020 IEC 62368-1:2018 GB 4943.1-2022 AS/NZS 62368.1:2022 RoHS 2011/65/EU RoHS 2015/863 REACH SVHC CA Prop 65 FCC 47 CFR Part 15B ICES-003 Issue 7 EN 55032:2015+A11 EN 55035:2017+A11 EN 61000-3-2:2014 EN 61000-3-3:2013+A1,A2 ICES-Gen Issue 1 + A1:2021
Environmental	Operating Temperature	0°C - 40°C (32°F - 104°F) Continuous
	Humidity	5% - 90% (non condensing)
Construction	Filter Housing	Aluminum w/Electroless Plated Nickel
	Dimensions	6.76" x 3.00" x 1.30"
	Mounting	1-20 UNEF-2A Mounting Stub for Threaded Penetration 1" NPS Threaded Penetration (1.32" Ø x 1", 3", 9", 12" or Custom)
	Power Requirements	+12VDC / 2A Minimum; Marked "LPS" or "Class 2" only. 2.1mm x 5.5mm; Center Positive
	Connectors	RJ-45 8P8C Jack (x2) 2.1mm x 5.5mm DC Barrel Jack
	Indicator LEDs	Power – Red When Power is Present Link Status (Input/Output) <ul style="list-style-type: none"> • 10Mbit - Red • 100Mbit - Green • 1Gbit – Dark Blue • 2.5Gbit - Yellow • 5Gbit - Purple • 10Gbit – Light Blue

Drawing

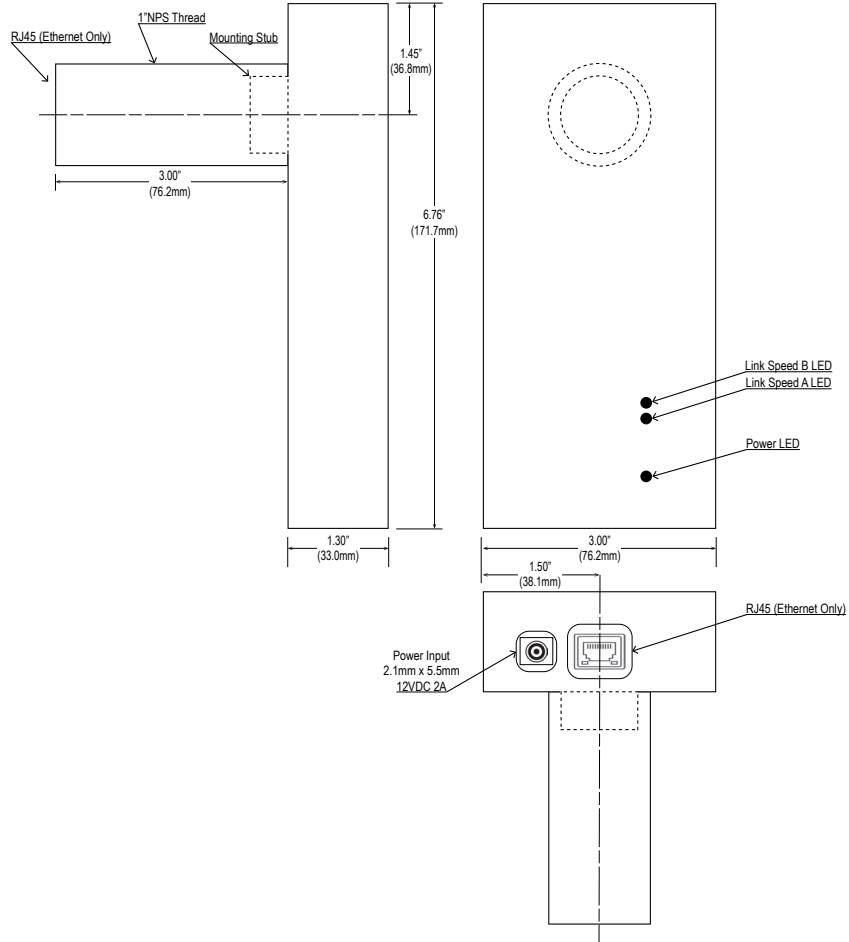

Connector Pinout

Pin	Ethernet (T568B)	
	Name	Description
1	BI_DA+	Bi-directional pair A +
2	BI_DA-	Bi-directional pair A -
3	BI_DB+	Bi-directional pair B +
4	BI_DC+	Bi-directional pair C +
5	BI_DC-	Bi-directional pair C -
6	BI_DB-	Bi-directional pair B -
7	BI_DD+	Bi-directional pair D +
8	BI_DD-	Bi-directional pair D -